

MV 5211

PV 6221



Elektrische Baureihen
Electric series
Seria elektryczna

- MV 5211
- MV 5214
- MV 5221
- MV 5224
- MV 5231
- MV 5234

Pneumatische Baureihen
Pneumatic series
Seria pneumatyczna

- PV 6211
- PV 6214
- PV 6221
- PV 6224
- PV 6231
- PV 6234

Ventile für die Drosselung, Mischung und Verteilung flüssiger und gasförmiger Medien

- Nennweite DN 15...100,
- Nenndruck PN 16...160,
- Durchgangs- und Dreiwegeform
- Ventilgehäuse aus
GJL250
GJS400-18-LT
GP240GH
GX5CrNiMo19-11-2
G17CrMo5-5
- Absperrkegel, Parabolkegel, Lochkegel, Kronenkegel, Misch-/ Verteilkegel

Valves for the throttling, mixing and diverting of liquids and gases

- Nominal diameter DN 15...100,
- Nominal pressure PN 16...160,
- Two-way and three-way design
- Valve body materials
GJL250
GJS400-18-LT
GP240GH
GX5CrNiMo19-11-2
G17CrMo5-5
- On-off plug, parabolic plug, perforated plug, V-port cone, Mixing-/ Diverting plug

Zawory do dławienia, mieszania i rozdzielania przepływu cieczy i gazów

- Średnica nominalna DN 15...100,
- Ciśnienie nominalne PN 16...160,
- Wersje dwu i trójdrogowe
- Materiały wykonania korpusów
GJL250
GJS400-18-LT
GP240GH
GX5CrNiMo19-11-2 G17CrMo5-5
- Grzyb odcinający, paraboliczny, perforowany, V-port, Mieszający / Rozdzielający

Absperr- und Regelventile Shut-off and control valves Zawory odcinające i regulacyjne

5200-7020

Technische Daten

<p>Baureihen: Faltenbalg Elektrisch Pneumatisch - ohne MV 5211 PV 6211 - mit MV 5214 PV 6214 - ohne MV 5221 PV 6221 - mit MV 5224 PV 6224 - ohne MV 5231 PV 6231 - mit MV 5234 PV 6234</p>	<p>Nennweiten: DN 15..100, Nenndrücke: PN 16..160, Gehäuse- : GJL-250 (PN16) werkstoffe GJS400-18LT (PN16; 25) GP240GH (PN16...160) G17CrMo5-5 (PN 63...160) GX5CrNiMo19-11-2 (PN16...40)</p>
<p>Flansche: Anschluss nach DIN 2501; Dichtleiste DIN 2526 Form C) andere Flanschbearbeitung z.B. nach EN 1092; Anschweißenden nach DIN 3239 oder DIN EN 12627</p>	<p>Spindelab- : PTFE-Kohle Packung (bis 250 °C) dichtungen Reingraphit Packung (bis 530 °C) (mediumsabhängig) Faltenbalgabdichtung mit Sicherheitsstopfbuchse (bis 350°C) mit DVGW- Zulassung (6 bar, 60°C) (siehe auch Datenblatt 5000-7060)</p>
<p>Kegelformen : Absperrkegel (Auf-Zu) (Kennlinie) Parabolkegel (gleich%/linear) Kronenkegel (linear) Lochkegel (gleich%/linear) Misch-/Verteilkegel (linear) für Dreiwegeventile (siehe auch Datenblatt 5000-7050)</p>	<p>Garniturwerk- : 1.4122/1.4308; Spindel+Sitz 1.4571 stoffe Parabolkegel aus Vollstellit Sitzpanzerung aus Stellit Lochkegel 1.4122 gehärtet Kegel und Sitz aus Ferro-Titanit</p>
<p>Kvs- Werte: siehe Tabelle 1-8</p>	

Technical data

<p>Series:bellows seal electric pneumatic - without MV 5211 PV 6211 - with MV 5214 PV 6214 - without MV 5221 PV 6221 - with MV 5224 PV 6224 - without MV 5231 PV 6231 - with MV 5234 PV 6234</p>	<p>Nominal diameter: DN 15..100, Nominal pressure: PN 16..160, Body materials: GJL-250 (PN16) GJS400-18LT (PN16; 25) GP240-GH (PN 16...160) G17CrMo5-5 (PN63...160) GX5CrNiMo19-11-2(PN16...40)</p>
<p>Flanges: connection acc.to DIN 2501; facing DIN 2526 FormC different flange manufacturing e.g. acc. EN 1092 Butt welded acc to DIN 3239 or EN 12627</p>	<p>Spindle packing PTFE/graphite (max. 250°C) pure graphite (max. 530°C) (medium dependent) bellows seal with safety stuffing box (max. 350°C) with DVGW-approval (6 bar, 60°C) (see data sheet 5000-7060)</p>
<p>Cone types: On/off plug (none) (characteristic parabolic plug (equal % / linear) Curve) V-port plug (linear) Perforated plug (equal %/linear) Mixing -/ Diverting plug (linear) for three way valves (See data sheet types 5000-7050).</p>	<p>Trim materials: 1.4122/1.4308; spindle+seat 1.4571 Parabolic cone full stellit stellited seat perforated plug 1.4122 hardened plug and seat of Ferro-Titanium</p>
<p>Kvs-values: see tables 1-8</p>	

Dane techniczne

<p>Seria: Mieszek uszcz. elektryczne pneumatyczne - brak MV 5211 PV 6211 - jest MV 5214 PV 6214 - brak MV 5221 PV 6221 - jest MV 5224 PV 6224 - brak MV 5231 PV 6231 - jest MV 5234 PV 6234</p>	<p>Średnica nominalna: DN 15..100; Ciśnienie nominalne: PN 16..160, Materiały korpusu : GJL-250 (PN 16) GJS-400-18LT (PN 16; 25) GP-240-GH (PN16...160) G17CrMo5-5 (PN 63...160) GX5CrNiMo19-11-2(PN16..40)</p>
<p>Kolnierze: połączenia w/g DIN 2501; wykonanie DIN 2526 Form C inne wykonania wg. EN 1092 Przyłącze spawane wg. DIN 3239 lub EN 12267</p>	<p>Uszczelnienie trzpienia: PTFE/Grafit (max. 250°C) Grafit (max. 530°C) (zależy od czynnika) uszczelnienie mieszkowe z dławnicą bezpieczeństwa (max.350°C) z zatwierdzeniem DVGW (6 bar, 60 °C) (patrz karta 5000-7060)</p>
<p>Wykonania grzyba: grzyb odcinający grzyb paraboliczny (stało%/ liniowy) Typu V-port (liniowy) Perforowany (stało % / liniowy) Mieszający-/Rozdzielający (liniowy) dla zaworów 3-drogowych (patrz karta 5000-7050).</p>	<p>Material zespołu grzyba : 1.4122/1.4308; trzpień + gniazdo 1.4571 Grzyb paraboliczny z pełnego stellitu. Stellitowane gniazdo grzyb perforowany 1.4122 utwardzony , grzyb i gniazdo z tytanu patrz tabela 1-8</p>
<p>Wartości Kvs :</p>	

Absperr- und Regelventile
Shut-off and control valves
Zawory odcinające i regulacyjne

5200-7030

Technische Daten

Leckage im Sitz: IV (<0,01% Kvs) metallisch dichtend
n.DIN EN 1349 IV-S2 (<0,005% Kvs) metallisch
eingeschliffen
VI (dichtschließend) weich dichtend
mit PTFE (max. +200°C)
Verteilkegel Tor B III (<0,1%Kvs)
Max.Druck/Temp.: nach DIN EN 1092
(siehe auch Datenblatt 5000-7030)
Zulassungen: ATEX (PV...)
GOST (MV..., PV...)
DGRL (MV..., PV...)

Technical data

Seat leakage: IV (<0,01% Kvs) metallic tight
acc..DIN EN 1349 IV-S2 (<0,005% Kvs) lapped in
VI (tight closing) soft seated with
PTFE (max. +200°C)
diverting cone port B III (<0,1%Kvs)
Max.press/temp.: acc. DIN EN 1092
(see data sheet 5000-7030)
Approvals: ATEX (PV...)
GOST (MV..., PV...)
DGRL (MV..., PV...)

Dane techniczne

Przeciek gniazda : IV (<0,01% Kvs) metal/metal
wg. DIN EN 1349 IV-S2 (<0,005% Kvs) docierany
VI (szczelny) z miękkim gniazdem
PTFE (max. +200°C)
grzyb rozdzielający port B III (<0,1%Kvs)
Max.: Ciśń./Temp.: wg. DIN EN 1092
(patrz karta 5000-7030)
Zatwierdzenia: ATEX (PV...)
GOST (MV..., PV...)
DGRL (MV..., PV...)

Technische Daten „Stellantrieb

siehe separate Technische Datenblätter :

Elektrischer Stellantrieb ST 5112	5112-7010
mit Schnellschlusseinrichtung ST6151	6150-7010
Pneumat. Stellantrieb ST 6115	6100-7010
Pneumat. Stellantrieb ST 6135	6100-7010

Technical data actuator

See separate technical data sheet

Electric Actuator ST 5112	5112-7010
with emergency closing unit ST 6151	6150-7010
Pneumatic Actuator ST 6115	6100-7010
Pneumatic Actuator ST 6135	6100-7010

Dane techniczne siłownika

Patrz osobne karty techniczne

Siłownik elektryczny ST 5112	5112-7010
z awaryjnym zamknięciem ST 6151	6150-7010
Siłownik pneumatyczny ST 6115	6100-7010
Siłownik pneumatyczny ST 6135	6100-7010

Tabelle / Table / Tableau 1 :		KVS-Werte / -Values / -Valeurs [m3/h]															
Parabolkegel / Parabolic plug / Clapet parabolique																	
EN	Sitz / Seat / Siège [mm]																
DN	4	4	4	8	8	12	12	15	20	25	32	40	50	65	80	100	
15	0,1	0,25	0,5	1	1,7	2,1	2,7	3,3									
20	0,1	0,25	0,5	1	1,7	2,5	3,7	4,2	6								
25	0,1	0,25	0,5	1	1,7	2,5	4	5,2	7,5	9,2							
32	0,1	0,25	0,5	1	1,7	2,5	4,4	6,3	9,4	11	15						
40	0,1	0,25	0,5	1	1,7	2,5	4,4	6,8	11	15	19	24					
50				1	1,7	2,5	4,4	6,8	12	18	24	30	37				
65						2,5	4,4	6,8	12	19	28	37	47	63			
80								6,8	12	18	31	45	58	78	95		
100									12	19	31	48	70	99	120	148	
Hub / Stroke / Course [mm]	25						30			35							

Tabelle / Table / Tableau 2 :		Kvs-Werte / -Values / -Valeurs [m3/h]										
Absperrkegel / on-off plug / clapet tout ou rien												
EN	Sitz / Seat / Siège [mm]											
DN	8	12	15	20	25	32	40	50	65	80	100	
15	1,7	2,7	3,3									
20	1,7	3,7	4,2	6								
25	1,7	4	5,2	7,5	9,2							
32		4,4	6,3	9,4	11	15						
40			6,8	11	15	19	24					
50				12	18	24	30	37				
65					19	28	37	47	63			
80						31	45	58	79	95		
100							48	70	99	120	148	
Hub / Stroke / Course [mm]	15						25		30			

Tabelle / Table / Tableau 3 :		Kvs-Werte / -values / -valeurs [m3/h]							
Kronenkegel / V-port plug / Clapet lanterne									
EN	Sitz / seat / siège [mm]								
DN	20	25	32	40	50	65	80	100	
20	6								
25	7,5	9,2							
32	9,4	11	15						
40	11	15	19	24					
50		18	24	30	37				
65		19	28	37	47	63			
80			31	45	58	79	95		
100				48	70	99	120	148	
Hub / Stroke / Course [mm]	15			25		30			

Bitte beachten :	
Pay attention :	
Faites attention s.v.p.	
Antriebs-Typ	max. Hub
Actuator type	max. Stroke
Type actionneur	Course max.
ST 5112	40 mm
ST 6115	25 mm
ST 6135	35 mm

Tabelle / Table / Tableau 4 : KVS-Werte / -Values / -Valeurs [m3/h]									
Lochkegel / Perforated plug / Clapet perforé									
EN	Sitz / Seat / Siège [mm]								
DN	12	15	20	25	32	40	50	65	80
15	1,6	2,6							
20	1,7	2,7	4,8						
25	1,7	2,7	4,8	7,2					
32	1,7	2,7	4,8	7,6	12				
40	1,7	2,7	4,8	7,6	12	19			
50	1,7	2,7	4,8	7,6	12	19	29		
65			4,8	7,6	13	19	30	49	
80				7,6	13	20	30	52	74
100				7,6	13	20	30	52	78
Hub / Stroke / Course [mm]	25			30			40		

Tabelle / Table / Tableau 5 :				KVS-Werte / -Values / -Valeurs [m3/h]			
		Mischkegel / Mixing plug / Clapet mélangeur				Verteilkegel / Diverting plug / Clapet répartiteur	
EN	Hub / Stroke / Course [mm]	Sitz / Seat / Siège [mm]	Kvs [m3/h]	Hub / Stroke / Course [mm]	Sitz / Seat / Siège [mm]	Kvs [m3/h]	
20	15	32	6	15	25	4,2	
25		32	9,2		25	7,5	
32		32	15		25	11	
40		40	24		32	19	
50		50	37		40	30	
65		65	63		50	47	
80	25	80	95	65	79		
100	30	100	148	80	129		

Table / Tabelle / Tableau 6 :													max. shut-off pressure [psi]		
													max. Schließdruck [psi]		
													max. pression de fermeture [psi]		
Actuator / Antrieb / Actionneur				Seat / Sitz / Siège [Inch.]											
				1/8	1/4	3/8	1/2	3/4	1	1 1/4	1 1/2	2	2 1/2	3	4
ST 5112 (3,0 kN)				580	580	580	580	580	580	363	232	145	87	58	43
ST 6115 / ST 6135				on request / auf Anfrage / sur demande											

Tabelle / Table / Tabela 7: Kvs-Werte /-Values/-Wartości [m³/h]									
Parabolkegel zweifachentspannt/ Multi stage parabolic plug Wielostopniowy grzyb paraboliczny									
EN	Sitz/Seat/Gniazdo[mm]								
DN	4	8	12	15					
15		0,7	1,5						
		1,2	2,0	2,4					
20		0,7	1,8						
		1,2	2,7	3,0					
25		0,7	1,8						
		1,2	4	3,7					
32		0,7	1,8						
		1,2	4,4	4,5					
40		0,7	1,8						
		1,2	4,4	5,0					
50		0,7	1,8						
		1,2	4,4	5,0					
65			1,8						
			4,4	5,0					
Hub/Stroke/ Skok [mm]	25								

Tabelle / Table / Tabela 8																			
Lochkegel zweifachentspannt / Multi stage perforated plug/ Wielostopniowy grzyb perforowany																			
EN	Sitz / Seat / Siege [mm]																		
DN	12	15	20	25	32	40	50	65	80	100	125	150	200	200	250	250	300	350	400
40			3,5	5,5	8,5														
50			3,5	5,5	8,5	13,5													
65			3,5	5,5	9,3	13,5	21												
80				5,5	9,3	14,3	21	37											
100				5,5	9,3	14,3	21	37	55										
125					9,3	14,3	21	37	55	86									
150						14,3	21	37	55	86	135								
200							21	37	55	86	135	195							
250								37	55	86	135	195	293	345					
300									55	86	135	195	293	345	515	555			
400												195	293	345	515	555	780	1055	
Hub/Stroke/ Skok [mm]	25			30			40	50	60	80	80	100	80	100	100	100	100	120	150

Maßblatt / Dimension sheet / Wymiary

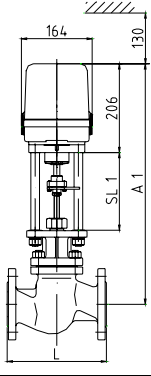
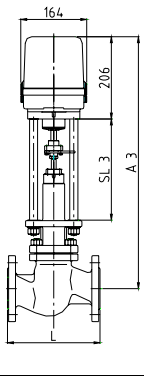
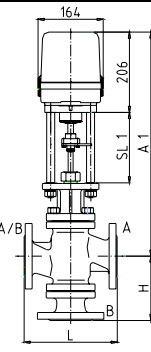
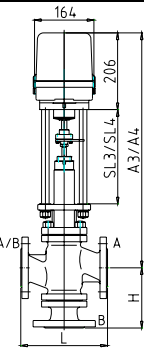
	<p>MV 5211 DN 15 – 100 PN 16 – 160</p>		<p>MV 5214 DN 15 – 100 PN 16 - 25</p>
	<p>MV 5221 MV 5231 DN 20 – 100 PN 16 – 160</p>		<p>MV 5224 MV 5234 DN 20 – 100 PN 16 - 25</p>

Mit Stellantrieb / with actuator/ z siłownikiem ST 5112				MV 5211/ MV 5221 MV 5231		MV 5214		MV 5224 MV 5234		Gewicht [kg] weight [kg] waga [kg]	
DN	PN	L	H	A1	SL1	A3	SL3	A4	SL4	2-W	3-W
15	16-40	130		520	180	634	295			10	
	63-160	210		623	225					15	
20	16-40	150	110	520	180	634	295	619	280	11	15
25	16-40	160	140	525	180	649	295	634	280	12	16
	63-160	230		656	225					22	27
32	16-40	180	140	530	180	654	295	639	280	14	17
	63-160	260									
40	16-40	200	162	553	180	676	295	661	280	17	22
	63-160	260	240	683	225					31	42
50	16-40	230	162	548	180	672	295	657	280	19	25
	63-160*	300	260	708	225					50	53
65	16-40	290	165	554	180	779	365	662	280	25	33
	63-160*	340	265	738	225					63	72
80	16-40	310	215	583	180	789	365	678	280	33	49
	63-160*	380	305	762	225					82	88
100	16-40	350	240	608	180	809	365	707	295	44	67
	63-160*	430	345	796	225					110	126

*Dreiwege-Ventile nur bis PN 100 möglich/*3-way valves up to PN 100 only / *Zawory trójdrogowe tylko do PN100

Maßblatt / Dimension sheet / Wymiary

	<p>PV 6211 DN 15 – 50 PN 16 – 40</p>		<p>PV 6214 DN 15 – 50 PN 16 / 25</p>
	<p>PV 6221 PV 6231 DN 20 – 50 PN 16 – 40</p>		<p>PV 6224 PV 6234 DN 20 – 50 PN 16 / 25</p>

Mit Stellantrieb / with actuator/ z silownikiem ST 6115.A6				PV 6211/ PV 6221 PV 6231		PV 6214		PV 6224 PV6234		Gewicht [kg] weight [kg] waga [kg]	
DN	PN	L	H	A1	SL1	A3	SL3	A4	SL4	2-W	3-W
15	16-40	130		464	211	587	335			8	
										13	
20	16-40	150	110	464	211	587	335	572	320	9	13
25	16-40	160	140	469	211	602	335	587	320	10	14
										20	
32	16-40	180	140	474	211	607	335	592	320	12	15
40	16-40	200	162	497	211	629	335	614	320	15	20
										29	
50	16-40	230	162	491	211	625	335	610	320	17	23
										34	

*Dreiwege-Ventile nur bis PN 100 möglich/*3-way valves up to PN 100 only / *Zawory trójdrogowe tylko do PN100

Die Bauhöhen der Ventile mit Ausrüstung Joch, sind identisch zu den Bauhöhen mit Ausrüstung Säulen, Faltenbalgventile ausgeschlossen.
 The height valves with yoke is identical to valves with pillars, except valves with bellow seal

Wysokość zaworu z jarzmem jest identyczna dla zaworów z kolumnami , za wyjątkiem wersji z mieszkiem uszczelniającym

	<p>PV 6211 DN 15 – 100 PN 16 – 160</p>		<p>PV 6214 DN 15 – 100 PN 16 / 25</p>
	<p>PV 6221 PV 6231 DN 20 – 100 PN 16 – 160</p>		<p>PV 6224 PV 6234 DN 20 – 100 PN 16 / 25</p>

Mit Stellantrieb / with actuator/ z siłownikiem ST 6135.B6				PV 6211/ PV 6221 PV 6231		PV 6214		PV 6224 PV 6234		Gewicht [kg] weight [kg] waga [kg]	
DN	PN	L	H	A1	SL1	A3	SL3	A4	SL4	2-W	3-W
15	16-40	130		484	211	607	335			10	
	63-160	210		587	255					18	
20	16-40	150	110	484	211	607	335	592	320	11	15
25	16-40	160	140	489	211	622	335	607	320	12	16
	63-160	230	213	620	255					26	30
32	16-40	180	140	494	211	627	335	613	320	14	17
40	16-40	200	162	517	211	648	335	633	320	17	22
	63-160	260	240	647	255					34	45
50	16-40	230	162	512	211	643	335	628	320	19	25
	63-160*	300	260	660	255					53	56
65	16-40	290	165	518	211	743	396	635	320	25	33
	63-160*	340	265	688	255					66	75
80	16-40	310	215	547	211	753	396	650	320	33	49
	63-160*	380	305	714	255					85	91
100	16-40	350	240	572	211	773	396	679	335	44	67
	63-160*	430	345	746	255					113	129

*Dreiwege-Ventile nur bis PN 100 möglich/*3-way valves up to PN 100 only / *Zawory trójdrogowe tylko do PN100

Die Bauhöhen der Ventile mit Ausrüstung Joch, sind identisch zu den Bauhöhen mit Ausrüstung Säulen, Faltenbalgventile ausgeschlossen.
 The height valves with yoke is identical to valves with pillars, except valves with bellow seal
 Wysokość zaworu z jarzmem jest identyczna dla zaworów z kolumnami , za wyjątkiem wersji z mieszkim uszczelniającym

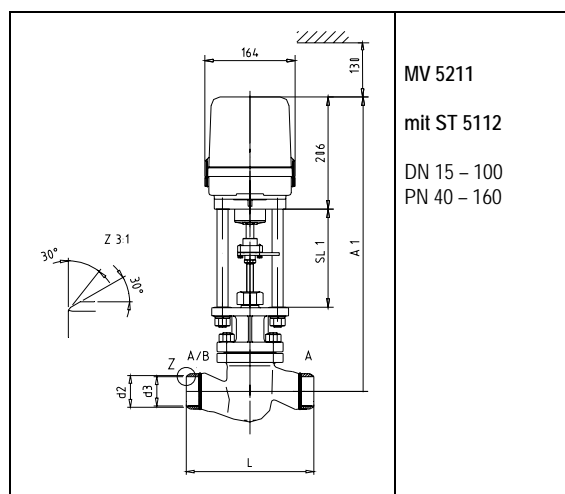

Anschweißendventil in Durchgangsform

mit Anschweißenden nach DIN 3239 – Teil 1 oder DIN EN 12627;
 Fugenform DIN 2559-21 (Andere auf Anfrage)
 Stutzen vorgeschuht: St 35.8 bei Gehäusematerial GP-240-
 GH15Mo3 bei Gehäusematerial G 17 CrMo 5-5

2 way valve with buttwelded ends

According to DIN 3239 – part 1 or EN 12627; edge form DIN 2559-
 21 (other on request)
 end connection: St 35.8 for body material GP-240-GH15Mo3 for
 body material G 17 CrMo 5-5

Zawory 2 drogowe z końcówkami do spawania

wg DIN 3239-część 1 lub DIN EN 12627; profil wg DIN 2559-21
 (inne na życzenie)
 końcówki : ST St 35.8 dla materiału korpusu GP- 240-GH
 15Mo3 dla materiału korpusu G 17 CrMo 5-5

PN	DN	15	20	25	32	40	50	65	80	100
PN 40	Baulänge L Face to face dimensions Wymiar L	130	130	130	160	180	210	290	310	350
	d2	22,0	28,0	34,0	43,0	49,0	61,0	76,1	88,9	114,3
	d3	17,0	22,0	28,5	37,0	43,0	54,0	69,0	81,0	104,0
	rura	21,3x 2,0	26,9x 2,3	33,7x 2,6	42,4x 2,6	48,3x 2,6	60,3x 3,2	76,1x 3,6	88,9x 4,0	114,3x 5,0
	A1	520	520	525	530	553	548	554	583	608
	SL1	180	180	180	180	180	180	180	180	180
	Gewicht [kg] weight [kg] Waga [kg]	8	9	10	12	14	16	21	28	38
PN 63 - 160	Baulänge L Face to face dimensions Wymiar L	150	150	160	180	210	380	420	460	510
	d2	22,0	28,0	34,0	43,0	49,0	61,0	77,0	90,0	115,0
PN 63	d3	17,0	22,0	28,5	37,0	43,0	54,0	69,0	81,0	104,0
	Rura	21,3x 2,0	26,9x 2,3	33,7x 2,6	42,4x 2,6	48,3x 2,6	60,3x 3,2	76,1x 3,6	88,9x 4,0	114,3x 5,0
PN 100	d3	17,0	22,0	28,5	37,0	43,0	54,0	69,0	81,0	104,0
	Rura	21,3x 2,0	26,9x 2,3	33,7x 2,6	42,4x 2,6	48,3x 2,6	60,3x 3,2	76,1x 3,6	88,9x 4,0	114,3x 5,0
PN 160	d3	17,0	22,0	27,0	35,0	41,0	52,5	65,0	76,5	98,5
	Rura	21,3x 2,0	26,9x 2,3	33,7x 3,2	42,4x 3,6	48,3x 3,6	60,3x 4,0	76,1x 5,6	88,9x 6,3	114,3x 8,0
PN 63 - 160	A1	623	*	656	*	683	708	738	762	796
	SL1	225	225	225	225	225	225	225	225	225
	Gewicht [kg] weight [kg] waga [kg]	12	*	18	*	26	42	55	70	102

*Daten auf Anfrage/ on request / * na zapytanie

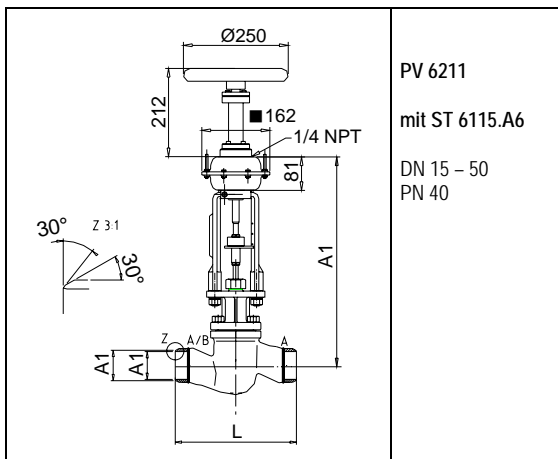

PV 6211
mit ST 6115.A6
 DN 15 – 50
 PN 40

Anschweißendventil in Durchgangsform

mit Anschweißenden nach DIN 3239 – Teil 1 oder DIN EN 12627;
 Fugenform DIN 2559-21 (Andere auf Anfrage)
 Stutzen vorgeschuht: St 35.8 bei Gehäusematerial GP-240-
 GH15Mo3 bei Gehäusematerial G 17 CrMo 5-5

2 way valve with butt-welded ends

According to DIN 3239 – part 1 or EN 12627; edge form DIN 2559-
 21 (other on request)
 end connection: St 35.8 for body material GP-240-GH15Mo3 for
 body material G 17 CrMo 5-5

Zawory 2 drogowe z końcówkami do spawania

wg DIN 3239-część 1 lub DIN EN 12627; profil w/g DIN
 2559-21 (inne na życzenie)

końcówki : ST St 35.8 dla materiału korpusu GP- 240-GH
 15Mo3 dla materiału korpusu G 17 CrMo 5-5

PN	DN	15	20	25	32	40	50
PN 40	Baulänge L Face to face dimensions Wymiar L	130	130	130	160	180	210
	d2	22,0	28,0	34,0	43,0	49,0	61,0
	d3	17,0	22,0	28,5	37,0	43,0	54,0
	Rura	21,3x 2,0	26,9x 2,3	33,7x 2,6	42,4x 2,6	48,3x 2,6	60,3x 3,2
	A1	423	423	428	433	456	451
	SL1	165	165	165	165	165	165
	Gewicht [kg] weight [kg] Waga [kg]	6	7	8	10	13	15

Die Bauhöhen der Ventile mit Ausrüstung Joch, sind identisch zu den Bauhöhen mit Ausrüstung Säulen, Faltenbalgventile ausgeschlossen.

The height valves with yoke is identical to valves with pillars, except valves with bellow seal

Wysokość zaworu z jarzmem jest identyczna dla zaworów z kolumnami , za wyjątkiem wersji z mieszkim uszczelniającym

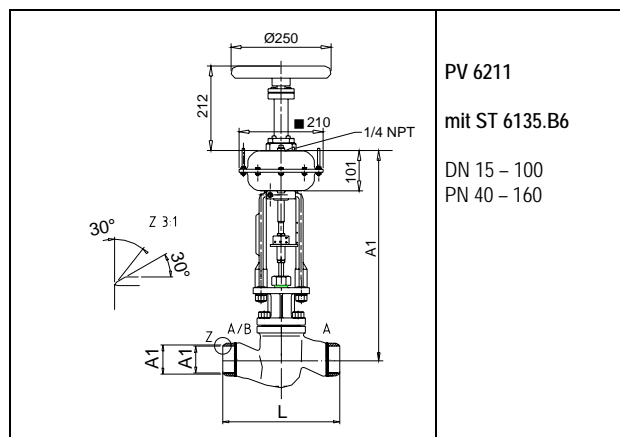

Anschweißendenventil in Durchgangsform

mit Anschweißenden nach DIN 3239 – Teil 1 oder DIN EN 12627; Fugenform DIN 2559-21 (Andere auf Anfrage)
 Stutzen vorgeschult: St 35.8 bei Gehäusematerial GP-240-GH15Mo3 bei Gehäusematerial G 17 CrMo 5-5

2 way valve with buttwelded ends

According to DIN 3239 – part 1 or EN 12627; edge form DIN 2559-21 (other on request)
 end connection: St 35.8 for body material GP-240-GH15Mo3 for body material G 17 CrMo 5-5

Zawory 2 drogowe z końcówkami do spawania

wg DIN 3239-część 1 lub DIN EN 12627; profil w/g DIN 2559-21 (inne na życzenie)
 końcówki : ST St 35.8 dla materiału korpusu GP- 240-GH 15Mo3 dla materiału korpusu G 17 CrMo 5-5

PN	DN	15	20	25	32	40	50	65	80	100
PN 40	Baulänge L Face to face dimensions Wymiar L	130	130	130	160	180	210	290	310	350
	d2	22,0	28,0	34,0	43,0	49,0	61,0	76,1	88,9	114,3
	d3	17,0	22,0	28,5	37,0	43,0	54,0	69,0	81,0	104,0
	Rura	21,3x 2,0	26,9x 2,3	33,7x 2,6	42,4x 2,6	48,3x 2,6	60,3x 3,2	76,1x 3,6	88,9x 4,0	114,3x 5,0
	A1	484	484							
	SL1	211	211	211	211	211	211	211	211	211
	Gewicht [kg] weight [kg] waga [kg]	9	10	11	13	15	17	22	29	39

PN	DN	15	20	25	32	40	50	65	80	100
PN 63 - 160	Baulänge L Face to face dimensions Wymiar L	150	150	160	180	210	380	420	460	510
	d2	22,0	28,0	34,0	43,0	49,0	61,0	77,0	90,0	115,0
PN 63	d3	17,0	22,0	28,5	37,0	43,0	54,0	69,0	81,0	104,0
	Rura	21,3x 2,0	26,9x 2,3	33,7x 2,6	42,4x 2,6	48,3x 2,6	60,3x 3,2	76,1x 3,6	88,9x 4,0	114,3x 5,0
PN 100	d3	17,0	22,0	28,5	37,0	43,0	54,0	69,0	81,0	104,0
	Rura	21,3x 2,0	26,9x 2,3	33,7x 2,6	42,4x 2,6	48,3x 2,6	60,3x 3,2	76,1x 3,6	88,9x 4,0	114,3x 5,0
PN 160	d3	17,0	22,0	27,0	35,0	41,0	52,5	65,0	76,5	98,5
	Rura	21,3x 2,0	26,9x 2,3	33,7x 3,2	42,4x 3,6	48,3x 3,6	60,3x 4,0	76,1x 5,6	88,9x 6,3	114,3x 8,0
PN 63 - 160	A1	587	*	620	*	647	660	688	714	746
	SL1	255	*	255	*	255	255	255	255	255
	Gewicht [kg] weight [kg] waga [kg]	14	*	20	*	28	45	58	73	105

*Daten auf Anfrage/ on request / na zapytanie

Die Bauhöhen der Ventile mit Ausrüstung Joch, sind identisch zu den Bauhöhen mit Ausrüstung Säulen, Faltenbalgventile ausgeschlossen.

The height valves with yoke is identical to valves with pillars, except valves with bellow seal

Wysokość zaworu z jzrzmem jest identyczna dla zaworów z kolumnami , za wyjątkiem wersji z mieszklem uszczelniającym

Ersatzteilliste / Spare parts list / Lista części zamiennych

Pos			D	GB	PL
101	GJL250; GJS400-18-LT; GP240GH;....	BVG...	Gehäuse	body	korpus
102	1.4571	FSIR...	Sitzring	seat ring	gniazdo
201	GJL250; GJS400-18-LT; GP240GH;....	BVD...	Deckel	bonnet	pokrywa
300		BVK....	Kegelgruppe	cone assembly	zespół grzyba
301	1.4122	FKKP...	Kegelkopf	cone head	grzyb
302	1.4571		Kegelspindel	cone spindle	trzczeń
303	1.4571		Metallbalg	metal bellow	mieszek
304	PTFE mit 25% Glasfaser		Führungsring	bush	piersień
400		CVSHHNAE	Spindelabdichtung PTFE- Kohle	spindle packing PTFE-graphite	uszczelnienie trzpienia PTFE-grafit
401	Ms 58		Überwurfmutter	cap nut	nakrętka dławnicy
402	Rg 7		Führungsbuchse	fairlead bush	docisk dławnicy
403	Rg 7		Führungsring	bush	tuleja
405	N 90		Abstreifring	scraper ring	piersień czyszczący
406	PTFE	GDID....	Dachmanschetten	chevron rings	piersienie chevron
407	1.4301		Scheibe	washer	podkładka
408	X 12 CrNi 177		Druckfeder	spring	sprężyna
409	NBR		O-Ring	o-ring	o-ring
420		CVSHONAE	Spindelabdichtung PTFE- Kohle	spindle packing PTFE- graphite	uszczelnienie trzpienia PTFE-grafit
421	Rg 7		Führungsbuchse	fairlead bush	docisk dławnicy
422	DIN 933-A2 M10X20		Sechskantschraube	bolt	śruba
423	N 90		Abstreifring	scraper ring	piersień czyszczący
424	PTFE	GDID....	Dachmanschetten	chevron rings	piersienie chevron
425	EPDM		O-Ring	o-ring	o-ring
427	1.4301		Scheibe	washer	podkładka
429	1.4310		Druckfeder	spring	sprężyna
430	Rg 7		Buchse	bush	tuleja
431	G-Bz 12		Buchse	bush	tuleja
440		CVSHHLOE	Spindelabdichtung Fallenbalg	Bellows seal with spindle packing	Uszczelnienie mieszkowe z dławnicą
441	1.4104		Überwurfmutter	cap nut	nakrętka
442	1.4301		Scheibe	washer	podkładka
443	DIN 933 - A2		Sechskantschraube	bolt	śruba
444	Reingraphit	FDIF...	Flachdichtring	gasket	uszczelka
445	PTFE weiß		Abstreifring	scraper ring	piersień czyszczący
446	PTFE weiß	GDID....	Dachmanschetten	chevron rings	piersienie chevron
447	1.4301		Scheibe	washer	podkładka
448	1.4310		Tellerfederpaket	spring washer	podkładka sprężynowa
449	DIN 913 - 45H verz.		Gewindestift	grub screw	śruba ustalająca
450	Klingersil C 4400		Dichtring	seal ring	piersień uszczelniający
451	DIN 933 - A2		Sechskantschraube	bolt	śruba
501	C 35 Y		Sechskantmutter	nut	nakrętka
502	Ck 35 Yk		Stiftschraube	stud	szpilka
503	Reingraphit	FDIF...	Flachdichtring	gasket	uszczelka
601	GJS400-18-LT; GP240GH	BVB...	B-Flansch	B-flange	Kolnierz-B

Pos			D	GB	FR
460		CVSHHRBE	Spindelabdichtung PTFE- Kohle	spindle packing PTFE-graphite	uszczelnienie trzpienia PTFE-grafit
461	Ms 58		Überwurfmutter	cap nut	nakrętka
462	Rg 7		Führungsbuchse	fairlead bush	docisk dławnicy
463	Rg 7		Führungsring	bush	tulejka
465	N 90		Abstreifring	scraper ring	pierścień czyszczący
466	PTFE	GDID....	Dachmanschetten	chevron rings	pierścienie chevron
467	1.4301		Scheibe	washer	podkładka
468	X 12 CrNi 177		Druckfeder	spring	sprężyna
469	NBR		O-Ring	o-ring	o-ring
800		CVSHHNA	Spindelabdichtung Grafit	spindle packing graphite	uszczelnienie trzpienia grafit
801	1.4301		Distanzrohr	spacer	tuleja dystansowa
802	Rg 7		Führungsring	bush	tulejka
803	Reingraphit		Presspackung	packing	dławnica
804	Rg 7		Stopfbuchse	stuffing box	docisk
805	Ms 58		Überwurfmutter	cap nut	nakrętka
820		CVSHONAA	Stopfbuchsabdichtung Grafit	spindle packing graphite	uszczelnienie trzpienia grafit
821	Rg 7		Buchse	bush	tulejka
822	Reingraphit		Presspackung	packing	dławnica
825	1.4541		Stopfbuchse	stuffing box	docisk dławnicy
826	DIN 938 1.4301		Stiftschraube	stud	śruba
827	DIN 934 1.4301		Sechskantmutter	nut	nakrętka
860		CVSHHRBA	Spindelabdichtung Grafit	spindle packing graphite	uszczelnienie trzpienia grafit
861	1.4301		Distanzrohr	spacer	tuleja dystansowa
862	Reingraphit		Führungsring	bush	tulejka
863	Rg 7		Presspackung	packing	dławnica
864	Rg 7		Überwurfmutter	cap nut	nakrętka

Ersatzteilliste / spare parts list / lista części zamiennych

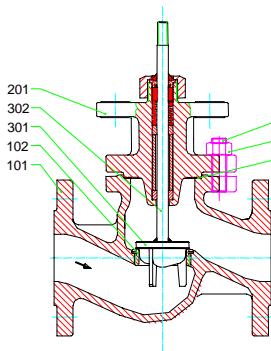

MV 5211, PV 6211
 DN 15-65, PN 16-40

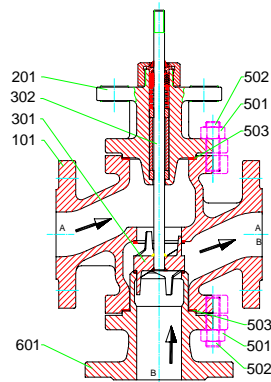

MV 5221, PV 6221
 DN 20-80, PN 16-40

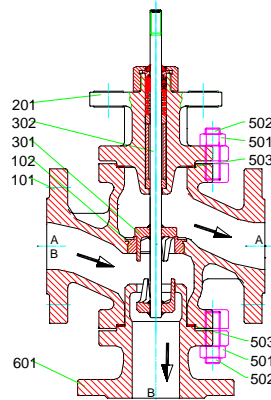

MV 5231, PV 6231
 DN 20-80, PN 16-40

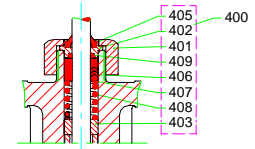

DN 15-65, PN 16-40

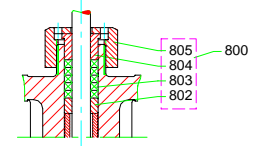

DN 15-65, PN 16-40

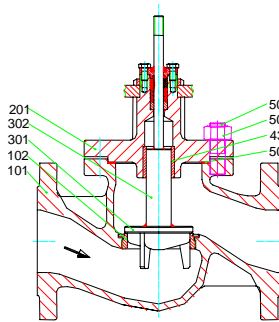

MV 5211, PV 6211
 DN 80-100, PN 16-40

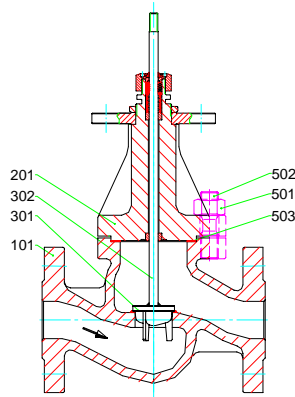

MV 5211, PV 6211
 DN 15-100, PN 63-160

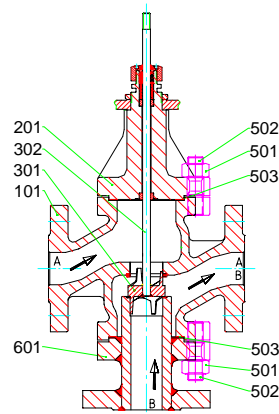

MV 5221, PV 6221
 DN 25-100, PN 63-160

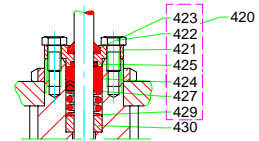

DN 80-100, PN 16-40

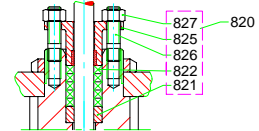

DN 80-100, PN 16-40

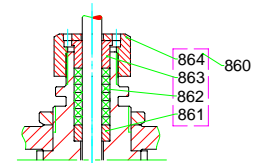

DN 80-100, PN 16-40

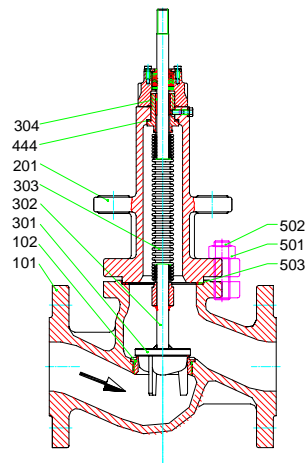

MV 5214, PV 6214
 DN 15-100, PN 16 / 25

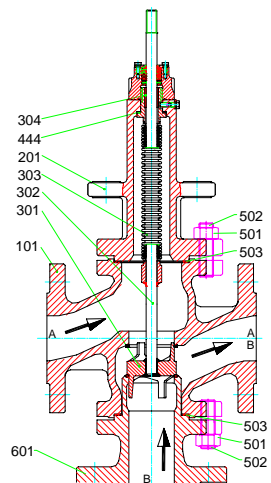

MV 5224, PV 6224
 DN 20-100, PN 16 / 25

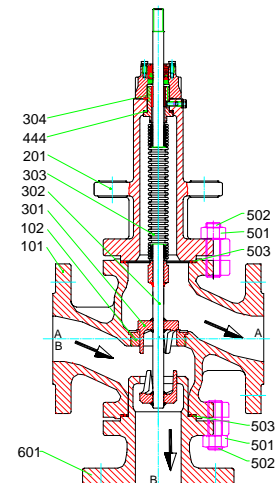

MV 5234, PV 6234
 DN 20-100, PN 16 / 25

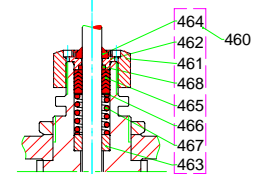

DN 15-50, PN 63-160

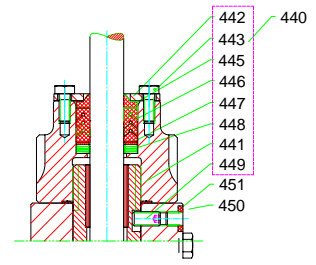

DN 20-100, PN 16-25

Technische Änderung vorbehalten / Subject to technical alteration / Podlegają zmianom technicznym